

Chicago Valves & Controls



SERIES XL

PNEUMATIC ACTUATORS

Design & Construction



1. Indicator

Indicator according to VID/VIE3845 is convenient for mounting accessories such as limit switch box, Positioner and etc.

2. Pinion

The design of the nickel-plated alloy steel integrated forging pinion drive is according the NAMUR,ISO5211 and DIN3337 standards. Special standard are available upon request.

3. Actuator Body

High quality aluminum alloy extrusion formed. The surface has been treated by anodized hardening followed by epoxy polyester coating. Other surface treatments are available e.g. PTFE and Nickel plating as well as other colour coatings on request.

4. End Cap

The surface has been treated by anodized hardening followed by epoxy polyester coating. Other surface treatments are available on request e.g. PTFE and Nickel plating as well as other colours on request.

5. Piston

Manufactured from Die-cast aluminum and treated by anodized hardening process. Symmetric mounting of the piston helps to ensure easy maintenance. Reverse action requirements can be achieved by inverting the pistons.

6. Adjusting Bolt

The two independent adjustment bolts can adjust opening and closing of the mounted valve within $\pm 5^\circ$.

7. Spring

Preloaded high grade springs with surface epoxy resin painted, which can be demounted conveniently to satisfy different requirements of torque by changing quantity of springs.

8. Piston Ring

Manufactured from low friction long life material POM. Can be easily changed for maintenance purposes.

9. O-rings

Standard NBR rubber O-rings provide trouble-free operation at standard temperature ranges. For other temperature requirements relevant materials can be offered on request.

10. Air Connection

Conforms to NAMUR standards

11. All stop parts are manufactured from SS304.

Explode View

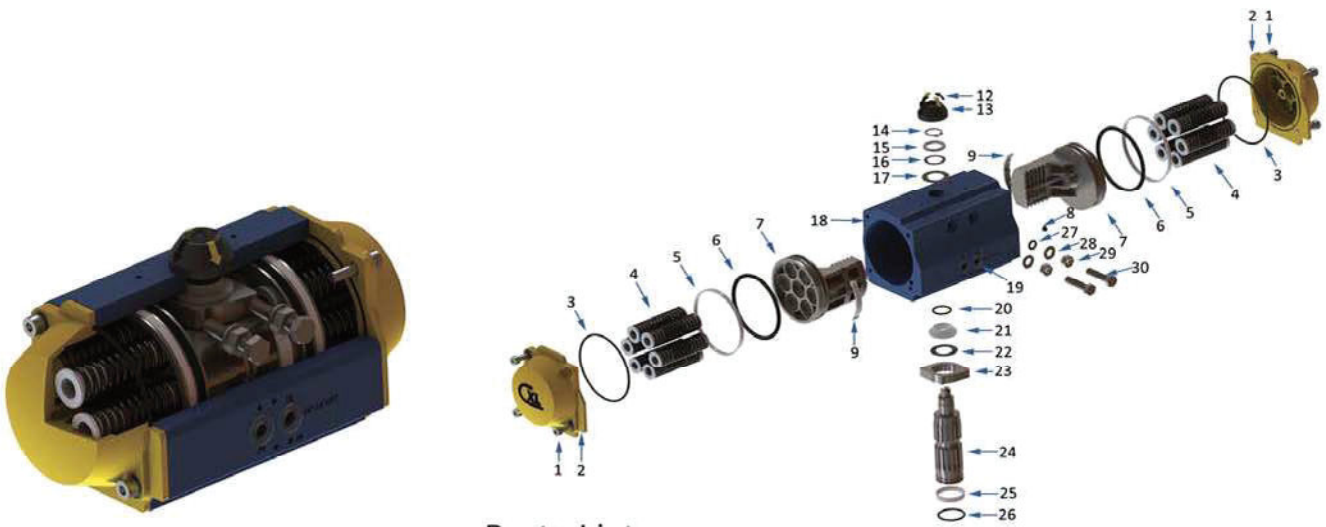

Parts List

No.	Part Description	Q.TY	Materials	Surface Treated	Optional Material
1	Socket Head Screw	8	SUS 304		
2	End Cap Seal	2	AL380 ≤ DFS 200 WCB ≥ DFS 240	Anode Hardening +Polyester Coating	CF8/CF8M
3*	"O"ring (Cylinder Head)	2	NBR Rubber		Viton / Silicone Rubber
4	Spring	2-12	Spring Steel	Epoxy resin Coating	
5*	Piston Ring	2	POM		
6*	"O"Ring (Piston)	2	NBR Rubber		Viton / Silicone Rubber
7	Piston	2	AL380	Anode Hardening	
8	Stopper	2	NBR Rubber		Viton / Silicone Rubber
9*	Guide Ring	2	PA6		
11	Indicator Bolt	1	ABS		
12	Indicator Arrowhead	4	ABS		
13	Indicator	1	ABS		
14	Snap Ring	1	Stainless Steel		
15	Washer	1	SUS 304		
16*	Disc Bearing	1	POM		
17	Washer	1	SUS 304		
18	Body	1	AL6063-T6	Anode Hardening +Polyester Coating	CF8/CF8M
19	Plug	2	PVC		
20*	"O"Ring (Pinion Top)	1	NBR Rubber		Viton / Silicone Rubber
21*	Bearing (pinion Top)	1	POM		
22	Disc Bearing	1	SUS 304		
23	Stroke Adjustment Stop	1	SAE 1020	Nickel Plated	CF8/CF8M
24	Pinion Shaft	1	SAE 1045	Nickel Plated	SUS304/SUS316
25*	Bearing(Pinion Bottom)	1	POM		
26*	"O" ring (pinion bottom)	1	NBR Rubber		Viton / Silicone Rubber
27*	"O"Ring (Adjusting Bolt)	2	NBR Rubber		Viton / Silicone Rubber
28	Metal Washer	2	SUS 304		
29	Nut	2	SUS 304		
30	Adjusting Bolt	2	SUS 304		

* Part Typically Supplied in Service Kits

Dimensions

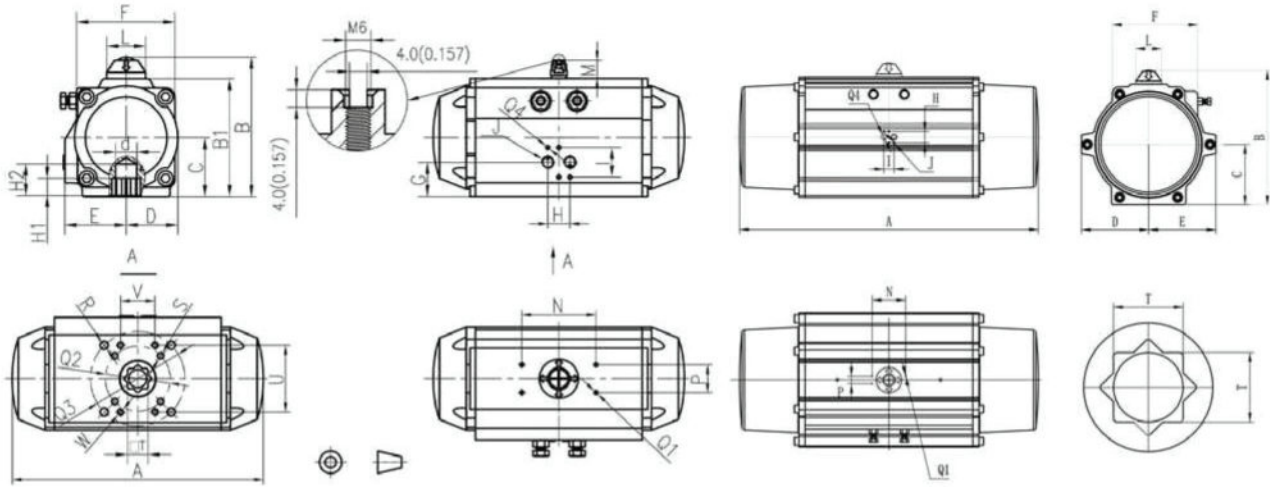

Imperial Unit Inch

Model Size	XL040	XL050	XL063	XL075	XL085	XL100	XL115	XL125	XL145	XL160	XL180	XL200	XL240	XL265	XL300	XL350	XL400
A	4.29	5.83	6.26	8.39	9.80	10.67	12.40	13.62	16.22	17.44	19.37	21.54	24.17	28.70	33.03	35.43	45.59
B	2.95	3.58	4.21	4.88	5.43	5.87	6.89	7.48	8.27	9.06	10.00	10.91	13.62	15.28	16.06	18.11	20.35
C	1.10	1.34	1.65	2.01	2.28	2.52	2.87	3.11	3.46	3.86	4.33	4.80	5.75	6.57	7.01	8.07	9.21
D	1.06	1.14	1.42	1.73	1.93	2.20	2.52	2.72	3.15	3.46	3.90	4.29	5.16	5.79	6.38	7.44	10.24
E	1.30	1.61	1.85	2.09	2.24	2.60	3.03	3.23	3.62	3.86	4.17	4.41	5.16	5.79	6.81	7.68	10.24
F	2.36	2.09	2.60	3.23	3.62	4.17	4.76	5.12	5.87	6.30	7.09	7.80	9.09	10.00	11.42	13.23	13.03
G	1.10	1.02	1.18	1.14	1.26	1.46	1.46	1.81	2.09	2.05	2.36	2.60	2.76	3.54	3.35	3.62	9.17
H	0.94	0.94	0.94	0.94	0.94	0.94	0.94	0.94	0.94	0.94	0.94	0.94	1.57	1.57	1.57	1.57	1.57
I	1.26	1.26	1.26	1.26	1.26	1.26	1.26	1.26	1.26	1.26	1.26	1.26	1.77	1.77	1.77	1.77	1.77
J	NPT1/8"	NPT1/4"	NPT1/4"	NPT1/4"	NPT1/4"	NPT1/4"	NPT1/4"	NPT1/4"	NPT1/4"	NPT1/4"	NPT1/4"	NPT1/4"	NPT3/8"	NPT3/8"	NPT1/2"	NPT1/2"	NPT1/2"
L	φ 1.18	φ 1.57	φ 1.57	φ 1.57	φ 1.57	φ 1.57	φ 2.36	φ 2.36	φ 2.36	φ 2.36	φ 3.15	φ 3.15	φ 3.15	φ 3.15	φ 3.15	φ 2.95	φ 2.95
M	0.79	0.79	0.79	0.79	0.79	0.79	1.18	1.18	1.18	1.18	1.18	1.18	1.97	1.97	1.97	1.97	1.97
N	1.61	3.15	3.15	3.15	3.15	3.15	3.15	3.15	3.15	3.15	5.12	5.12	5.12	5.12	5.12	5.12	5.12
P	1.18	1.18	1.18	1.18	1.18	1.18	1.18	1.18	1.18	1.18	1.18	1.18	1.18	1.18	1.18	1.18	1.18
Q1	M5	M5	M5	M5	M5	M5	M5	M5	M5	M5	M5	M5	M5	M5	M5	M5	M5
Q2	F03	F04	F05	F05	F05	F07	F07	F10	F10	F10	F10	F10	F12	-	-	-	F25
Q3	F05	-	F07	F07	F07	F10	F10	-	F12	F12	F14	F14	F16	F16	F16	F25	-
Q4	M5	M5	M5	M5	M5	M5	M5	M5	M5	M5	M5	M5	M6	M6	M6	M6	M6
R	4-M6	-	4-M8	4-M8	4-M8	4-M10	4-M10	-	4-M12	4-M12	4-M16	4-M16	4-M20	4-M20	4-M20	8-M16	-
S	4-M5	4-M5	4-M6	4-M6	4-M6	4-M8	4-M8	4-M10	4-M10	4-M10	4-M10	4-M10	4-M12	-	-	-	8-M16
T	0.35	0.67	0.67	0.87	0.87	0.87	0.87	1.42	1.42	1.42	1.42	1.42	1.81	1.81	1.81	2.17	2.17
H1	0.43	0.47	0.63	0.75	0.75	0.91	0.91	1.14	1.14	1.14	1.65	1.65	1.97	1.97	1.97	2.36	2.36
d	-	φ 0.56	φ 0.56	φ 0.77	φ 0.77	φ 0.91	φ 0.91	φ 1.42	φ 1.42	φ 1.42	φ 1.50	φ 1.50	φ 1.89	φ 1.89	φ 1.89	φ 2.17	φ 2.17
H2	-	1.26	1.34	1.34	1.34	1.89	1.89	2.56	2.56	2.56	3.62	3.62	3.62	3.62	3.62	3.94	3.94
U	-	-	-	-	-	2.83	2.83	2.83	2.83	2.83	3.90	3.90	-	-	-	-	-
V	-	-	-	-	-	1.46	1.46	1.46	1.46	1.46	2.09	2.09	-	-	-	-	-
W	-	-	-	-	-	M8	M8	M8	M8	M8	M10	M10	-	-	-	-	-

1. Top mounting connection is in line with VDI/VDE3845 standards, permitting direct installation of accessories such as positioner or limit switch box.
2. Bottom mounting connection is in line with ISO5211 and DIN3337 standards.
3. Air supply connection is in line with VDI/VDE3845 and NAMUR standards, and can install solenoid valves conveniently.

Weight & Air Consumption

Imperial Unit Inch

Data Model	Body Diameter	Air Consumption Per Stroke Actual Volume/L		Opening Time DA	Closing Time DA	Approximate Weight-DA	Approximate Weight - Spring
	Φ (In)	CCW (L)	CW (L)	S (sec.)	S (sec.)	lb	lb
XL040	1.57	0.032	0.068	0.14	0.16	1.53	small 0.0110 big 0.0250
XL050	1.97	0.08	0.13	0.17	0.19	2.38	0.0186
XL063	2.48	0.15	0.25	0.19	0.22	3.42	0.0313
XL075	2.95	0.30	0.48	0.23	0.27	6.06	0.0763
XL085	3.46	0.50	0.73	0.33	0.35	8.33	0.1202
XL100	3.94	0.75	1.08	0.42	0.48	11.68	0.1687
XL115	4.53	1.19	1.8	0.72	0.93	18.5	0.2337
XL125	4.92	1.55	2.18	0.84	1.09	21.89	0.3426
XL145	5.71	2.40	3.55	1.32	1.42	31.08	0.5090
XL160	6.30	3.20	4.72	1.6	2.0	40.45	0.6812
XL180	7.09	4.30	6.80	2	2.4	55.12	1.0803
XL200	7.87	5.87	9.53	2.7	3.5	77.16	2.0900
XL240	9.45	10	15	3.5	4.5	138.89	3.7808
XL265	10.63	15	23	4.5	5.0	174.16	5.2425
XL300	11.81	21.1	30.5	8.8	12.7	299.39	6.8343
XL350	13.780	30.8	44.4	13	19	516.54	10.362
XL400	15.75	48.3	69.6	20	29	745.16	18.761

* The above indicated moving time of the actuator, are obtained in the following testcons:

- (1) Room temperature
- (2) Actuator stroke 90°
- (3) Solenoid valve with orifice of 4mm and flow capacity QN 400L/min.
- (4) Inside pipe diameter 5mm
- (5) Medium clean air
- (6) Air supply pressure 5.5 bar (79.75psi)
- (7) Actuator without external resistance load

Output Torque of Double Acting Actuator(inch)

Imperial unit in-lb :

Output Torque of Double Acting Actuator							
Model \ Air Pressure	40PSI	60PSI	70PSI	80PSI	90PSI	100PSI	120PSI
XL040	41	64	77	89	101	113	137
XL050	77	110	135	155	174	201	243
XL063	130	197	245	275	311	340	421
XL075	277	430	500	559	632	702	833
XL085	431	641	752	870	970	1081	1328
XL100	623	952	1085	1261	1419	1604	1959
XL115	1050	1556	1837	2095	2362	2625	3149
XL125	1327	1923	2289	2664	3003	3357	4047
XL145	1872	2884	3588	4102	4862	5145	6317
XL160	2849	4120	4784	5549	6180	6871	8331
XL180	3622	5557	6492	7529	8331	9278	11325
XL200	5087	7690	9037	10344	11536	12748	15390
XL240	8709	13138	15248	17492	19684	21869	26230
XL265	14203	21240	24772	28413	32044	35577	42755
XL300	17865	26798	31443	35738	40201	44663	53595
XL350	26086	39130	45862	52173	58695	65215	78251
XL400	40891	61322	71881	81775	91993	102213	122654

Output Torque of Spring Return Actuator(inch)

Imperial unit in-lb:

Model	Size Springs Qty	Output Torque of Spring Return Actuator														Spring Return	
		40PSI		60PSI		70PSI		80PSI		90PSI		100PSI		120PSI		START	END
		START	END	START	END	START	END	START	END	START	END	START	END	START	END		
XL040	2					51	33	62	45	73	56	87	69	110	93	44	27
	4									55	21	70	34	92	58	80	44
XL050	5	53	39	82	67	109	95	129	114	146	131	174	160	215	200	42	27
	6	46	31	75	58	103	86	122	105	139	122	167	151	208	190	50	34
	7	41	23	69	49	97	78	115	96	133	113	161	142	201	181	59	40
	8			61	38	90	68	108	86	125	103	154	133	194	171	69	47
	9			55	30	84	61	102	78	119	94	148	125	188	163	77	53
	10					78	53	96	70	113	86	142	117	181	155	85	59
	11					71	44	89	60	105	76	135	107	174	145	95	66
	12					64	34	82	51	98	66	128	98	167	135	104	73
XL063	5	84	60	145	118	197	172	225	199	259	233	290	265	369	342	76	50
	6	75	46	135	102	187	156	215	183	249	216	281	249	359	326	92	60
	7	66	31	125	85	178	141	205	167	239	200	271	234	349	309	108	70
	8			114	70	167	127	194	153	228	185	261	220	338	295	122	81
	9			103	54	157	112	184	137	217	168	250	204	327	278	138	91
	10			92	38	147	97	173	121	206	152	240	188	316	262	154	102
	11					138	81	163	105	196	135	230	173	306	245	170	112
	12					128	67	154	90	186	120	221	158	296	230	185	121
XL075	5	183	130	325	266	402	346	457	399	526	467	602	545	728	668	159	102
	6	167	102	307	233	385	316	439	368	508	435	584	514	710	636	190	119
	7	149	73	287	201	366	286	420	337	488	403	565	484	689	604	221	139
	8			266	169	346	256	399	306	467	371	545	453	668	572	252	159
	9			246	137	328	226	381	275	448	339	527	423	649	540	283	178
	10			226	105	309	197	361	244	428	307	507	392	629	508	314	197
	11					291	167	342	213	407	275	488	362	609	476	345	217
	12					272	137	322	182	387	243	469	331	589	444	376	236
XL085	5	278	187	469	366	591	496	703	604	798	696	917	820	1155	1053	266	166
	6	248	140	435	313	560	446	670	552	764	643	885	769	1122	1000	317	199
	7	218	93	401	260	528	396	637	501	731	590	853	718	1088	947	368	232
	8			368	207	497	347	605	449	698	536	821	668	1055	894	419	264
	9			335	154	467	297	574	398	665	483	790	617	1022	840	471	296
	10			301	101	435	248	541	346	631	430	758	567	988	787	522	328
	11					403	198	508	295	597	377	725	516	954	734	573	361
	12					372	149	475	243	563	324	693	466	920	681	625	394
XL100	5	418	305	722	595	871	752	1038	914	1189	1062	1385	1264	1729	1602	345	222
	6	377	241	676	523	827	684	993	844	1143	990	1341	1195	1683	1530	415	267
	7	335	177	629	450	784	617	947	774	1096	917	1297	1127	1636	1458	485	312
	8			582	378	740	549	902	704	1049	845	1252	1058	1589	1385	555	358
	9			536	306	696	482	857	634	1002	773	1208	989	1543	1313	625	403
	10			490	234	654	415	812	565	957	701	1164	921	1497	1241	694	447
	11					610	348	767	494	910	629	1120	852	1450	1169	764	492
	12					566	280	721	424	862	557	1074	783	1403	1097	834	538

Output Torque of Spring Return Actuator(inch)

Imperial unit in-lb:

Model	Size	Springs Qty	Output Torque of Spring Return Actuator														Spring Return	
			40PSI		60PSI		70PSI		80PSI		90PSI		100PSI		120PSI		START	END
			START	END	START	END	START	END	START	END	START	END	START	END	START	END		
XL115	5	716	513	1199	970	1487	1273	1731	1509	1987	1758	2267	2049	2774	2554	584	363	
	6	651	407	1126	851	1418	1162	1660	1403	1913	1648	2197	1936	2701	2435	699	434	
	7	586	301	1053	732	1350	1051	1589	1287	1831	1520	2127	1822	2628	2307	814	504	
	8			970	613	1273	940	1518	1172	1758	1401	2049	1709	2554	2188	929	584	
	9			897	494	1205	829	1447	1048	1685	1282	1979	1596	2472	2069	1044	655	
	10					1136	718	1367	932	1611	1163	1910	1482	2399	1950	1159	726	
	11					1068	607	1296	817	1538	1044	1840	1369	2325	1831	1274	797	
	12							1225	701	1456	925	1761	1256	2243	1712	1389	867	
XL125	5	911	667	1456	1181	1854	1598	2211	1944	2536	2261	2912	2651	3580	3305	717	451	
	6	826	529	1360	1025	1765	1453	2117	1793	2440	2106	2821	2502	3484	3149	867	544	
	7	741	399	1263	879	1675	1316	2024	1651	2344	1959	2729	2363	3387	3003	1009	637	
	8			1163	723	1581	1171	1926	1500	2243	1804	2633	2215	3287	2847	1159	735	
	9			1067	568	1491	1025	1833	1349	2147	1648	2542	2066	3191	2692	1310	827	
	10					1401	880	1740	1198	2051	1492	2450	1918	3094	2536	1460	920	
	11					1312	743	1647	1056	1955	1346	2359	1779	2998	2390	1602	1013	
	12					1218	598	1549	906	1854	1190	2263	1630	2898	2234	1752	1111	
XL145	5	1213	838	2142	1721	2897	2504	3382	2974	4120	3699	4438	4037	5576	5154	1124	717	
	6	1074	627	1987	1483	2751	2281	3231	2743	3964	3461	4290	3810	5420	4916	1354	867	
	7	936	415	1831	1245	2606	2059	3081	2512	3809	3223	4142	3584	5264	4678	1584	1018	
	8			1685	1007	2469	1837	2939	2282	3662	2985	4002	3357	5118	4440	1814	1159	
	9			1529	778	2324	1624	2788	2060	3506	2756	3854	3139	4962	4211	2036	1310	
	10			1373	540	2179	1401	2637	1829	3351	2518	3706	2912	4806	3973	2266	1460	
	11					2042	1179	2495	1598	3204	2280	3566	2686	4660	3735	2496	1602	
	12					1905	957	2353	1367	3058	2042	3427	2459	4514	3497	2726	1743	
XL160	5	1953	1506	3113	2609	3845	3375	4572	4084	5173	4669	5912	5432	7324	6821	1460	974	
	6	1766	1237	2902	2307	3649	3093	4368	3791	4962	4367	5711	5144	7114	6518	1752	1177	
	7	1579	960	2692	1996	3452	2803	4164	3489	4752	4056	5511	4848	6903	6207	2053	1381	
	8			2481	1694	3256	2521	3959	3196	4541	3754	5310	4560	6692	5905	2345	1584	
	9			2280	1382	3068	2230	3764	2894	4340	3442	5118	4264	6491	5594	2646	1779	
	10			2069	1080	2871	1948	3560	2601	4129	3140	4918	3976	6280	5292	2938	1982	
	11					2675	1658	3356	2299	3918	2829	4717	3680	6070	4980	3239	2186	
	12					2487	1376	3160	2006	3717	2527	4525	3392	5868	4678	3531	2381	
XL180	5	2352	1676	4129	3369	5161	4452	6143	5407	6903	6143	7917	7193	9897	9137	2115	1381	
	6	2091	1294	3836	2939	4888	4050	5859	4989	6610	5713	7638	6784	9604	8707	2531	1664	
	7	1831	911	3543	2509	4614	3649	5575	4572	6317	5283	7359	6374	9311	8276	2947	1947	
	8			3250	2069	4341	3238	5291	4146	6024	4843	7080	5955	9018	7837	3372	2230	
	9			2966	1639	4076	2837	5016	3729	5740	4413	6810	5545	8734	7407	3788	2505	
	10			2673	1208	3802	2435	4732	3311	5447	3983	6531	5136	8441	6976	4204	2788	
	11					3538	2034	4457	2894	5164	3552	6260	4726	8157	6546	4620	3062	
	12					3264	1632	4173	2477	4871	3122	5981	4316	7864	6116	5036	3345	
XL200	5	3328	2498	5713	4779	7195	6323	8425	7519	9558	8624	10864	9975	13412	12479	2814	1912	
	6	2987	1986	5328	4202	6836	5785	8052	6960	9173	8047	10498	9425	13028	11902	3372	2283	
	7	2645	1473	4944	3625	6477	5247	7679	6401	8789	7471	10132	8876	12643	11325	3929	2655	
	8			4559	3058	6118	4717	7306	5850	8404	6903	9766	8336	12259	10757	4478	3027	
	9			4166	2490	5751	4187	6925	5300	8011	6335	9391	7795	11865	10190	5027	3407	
	10			3772	1913	5383	3649	6543	4741	7617	5759	9016	7246	11471	9613	5584	3788	
	11					5024	3119	6170	4190	7233	5191	8649	6705	11087	9045	6133	4160	
	12					4657	2581	5788	3631	6839	4614	8275	6156	10693	8469	6691	4540	

Output Torque of Spring Return Actuator(inch)

Imperial unit in-lb:

Model	Size Springs Qty	Output Torque of Spring Return Actuator														Spring Return	
		40PSI		60PSI		70PSI		80PSI		90PSI		100PSI		120PSI		START	END
		START	END	START	END	START	END	START	END	START	END	START	END	START	END		
XL240	5	5737	4419	9796	8313	12134	10749	14249	12811	16342	14859	18685	17273	22888	21405	4664	3230
	6	5135	3564	9119	7352	11501	9852	13592	11878	15665	13898	18040	16357	22210	20444	5593	3885
	7	4541	2694	8450	6372	10878	8938	12944	10929	14996	12936	17395	15450	21524	19482	6540	4531
	8			7736	5402	10245	8032	12287	9987	14319	11975	16758	14535	20846	18521	7478	5186
	9			7123	4449	9639	7143	11656	9064	13669	11014	16113	13628	20160	17560	8399	5814
	10			6445	3506	9006	6263	11000	8150	12991	10052	15459	12713	19491	16589	9310	6469
	11					8374	5358	10343	7209	12314	9100	14823	11788	18814	15637	10248	7124
	12					7742	4426	9686	6241	11636	8148	14169	10882	18127	14667	11213	7779
XL265	5	9790	7690	16278	13916	20149	17944	23597	21307	27081	24719	30849	28599	37793	35431	7080	4797
	6	8887	6429	15298	12479	19217	16577	22629	19886	26083	23254	29898	27204	36795	33966	8452	5779
	7	8016	5119	14319	11041	18286	15210	21742	18466	22613	21789	28948	25809	35797	32501	9877	6726
	8			13339	9567	17355	13843	20685	17045	24087	20324	27997	24414	34799	31036	11284	7655
	9			12359	8111	16423	12475	19726	15625	23089	18860	27047	23019	33709	29571	12744	8673
	10			11297	6628	15492	11108	18759	14204	22091	17395	26097	21624	32803	28106	14125	9611
	11					14560	9741	17791	12784	21094	15930	25146	20229	31805	26642	15523	10558
	12					13672	8459	16823	11364	20096	14465	24196	18833	30807	25177	16904	11505
XL300	5	11857	8854	20041	16662	25147	21994	29181	25905	33444	30066	38225	35008	46838	43460	9797	6531
	6	10661	7064	18695	14648	23891	20115	27876	23952	32098	28051	36943	33089	45492	41445	11744	7832
	7	9464	5265	17349	12625	22635	18226	26571	21990	30752	26028	35662	31162	44146	39422	13700	9133
	8			16003	10602	21379	16338	25266	20028	29406	24005	34380	29236	42800	37399	15656	10434
	9			14648	8578	20115	14449	23952	18066	28051	21982	33089	27309	41445	35376	17612	11744
	10			13302	6555	18858	12561	22647	16104	26706	19958	31808	25382	40100	33352	19567	13045
	11					17602	10672	21342	14142	25360	17935	30526	23455	38754	31329	21523	14346
	12							20071	12247	24525	16701	28993	21169	37912	30088	23481	15657
XL350	5	17326	12947	29278	24353	36683	32086	42613	37837	48843	43917	55829	51138	68398	63473	14284	9523
	6	15576	10327	27310	21405	34846	29334	40704	34978	46874	40969	53954	48331	66430	60525	17134	11425
	7	13834	7707	25351	18457	33017	26583	38805	32120	44915	38021	52089	45523	64471	57577	19983	13319
	8			23382	15509	31180	23832	36896	29261	42947	35073	50214	42715	62502	54629	22833	15222
	9			21414	12561	29343	21080	34987	26402	40979	32126	48339	39908	60534	51681	25683	17125
	10			19446	9613	27506	18329	33078	23544	39010	29178	46465	37100	58566	48733	28532	19028
	11					25677	15577	31179	20685	37051	26230	44599	34293	56606	45785	31382	20921
	12							29333	17915	35840	24422	42370	30952	55387	43969	34244	22826
XL400	5	27189	20337	45913	38205	57524	50329	66823	59348	76583	68874	87532	80191	107244	99535	22346	14895
	6	24446	16227	42828	33581	54644	46014	63831	54864	73498	64251	84594	75787	104158	94912	26816	17877
	7	21712	12117	39752	28958	51773	41699	60848	50381	70422	59628	81664	71384	101082	90288	31285	20851
	8			36666	24334	48894	37384	57856	45898	67336	55004	78726	66981	97997	85665	35754	23833
	9			33590	19711	46022	33068	54873	41415	64260	50381	75796	62578	94921	81042	40223	26807
	10			30505	15088	43143	28753	51882	36931	61175	45758	72858	58175	91836	76418	44693	29789
	11					40263	24438	48890	32448	58090	41134	69919	53771	88750	71795	49162	32772
	12							45907	27965	55013	36511	66990	49368	85674	67172	53631	35745

CXL INSERTS

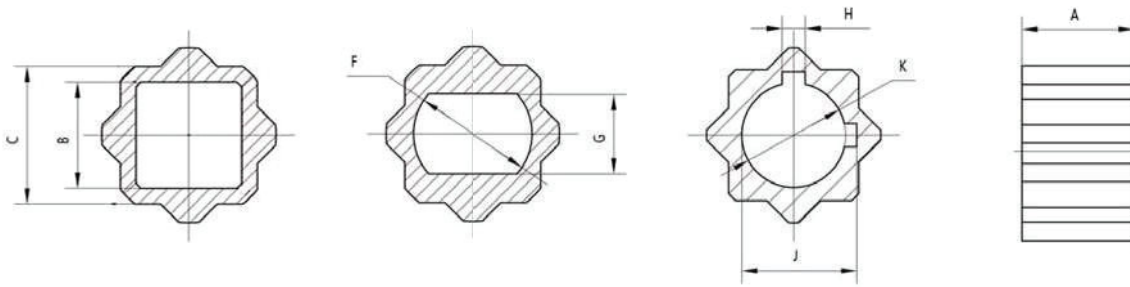

Model	Insert Code	Insert Shape	Unit	Insert Size	A	B	C	F	G	H	J	K
050	A	Square	in mm	0.354 9	0.472 12	0.354 9	0.669 17					
	B*	Square	in mm	0.433 11	0.472 12	0.433 11	0.669 17					
	C	Square	in mm	0.551 14	0.472 12	0.551 14	0.669 17					
	G	Flat	in mm	0.378 10	0.472 12		0.669 17	0.567 14	0.378 10			
063	A	Square	in mm	0.354 9	0.63 16	0.354 9	0.669 17					
	B*	Square	in mm	0.433 11	0.63 16	0.433 11	0.669 17					
	C	Square	in mm	0.551 14	0.63 16	0.551 14	0.669 17					
	G	Flat	in mm	0.378 10	0.63 16		0.669 17	0.567 14	0.378 10			
075&085	A	Square	in mm	0.354 9	0.709 18	0.354 9	0.866 22					
	B	Square	in mm	0.433 11	0.709 18	0.433 11	0.866 22					
	C*	Square	in mm	0.551 14	0.709 18	0.551 14	0.866 22					
	D	Square	in mm	0.669 17	0.709 18	0.669 17	0.866 22					
	G	Flat	in mm	0.378 10	0.709 18		0.866 22	0.567 14	0.378 10			
	H	Flat	in mm	0.441 11	0.709 18		0.866 22	0.63 16	0.441 11			
	I	Flat	in mm	0.503 13	0.709 18		0.866 22	0.756 19	0.503 13			
100&115	B	Square	in mm	0.433 11	0.906 23	0.433 11	0.866 22					
	C	Square	in mm	0.551 14	0.906 23	0.551 14	0.866 22					
	D*	Square	in mm	0.669 17	0.906 23	0.669 17	0.866 22					
	G	Flat	in mm	0.378 10	0.906 23		0.866 22	0.567 14	0.378 10			
	H	Flat	in mm	0.441 11	0.906 23		0.866 22	0.63 16	0.441 11			
	I	Flat	in mm	0.503 13	0.906 23		0.866 22	0.756 19	0.503 13			
125, 145&160	C	Square	in mm	0.551 14	1.142 29	0.551 14	1.417 36					
	D	Square	in mm	0.669 17	1.142 29	0.669 17	1.417 36					
	E	Square	in mm	0.866 22	1.142 29	0.866 22	1.417 36					
	F*	Square	in mm	1.063 27	1.142 29	1.063 27	1.417 36					
	G	Flat	in mm	0.378 10	1.142 29		1.417 36	0.567 14	0.378 10			
	H	Flat	in mm	0.441 11	1.142 29		1.417 36	0.63 16	0.441 11			
	I	Flat	in mm	0.503 13	1.142 29		1.417 36	0.756 19	0.503 13			
	J	Flat	in mm	0.628 16	1.142 29		1.417 36	0.882 22	0.628 16			
	K	Round	in mm	1.13 29	1.142 29		1.417 36			0.252 6	1.252 32	1.13 29
180&200	E	Square	in mm	0.866 22	1.654 42	0.866 22	1.417 36					
	F*	Square	in mm	1.063 27	1.654 42	1.063 27	1.417 36					
	J	Flat	in mm	0.628 16	1.654 42		1.417 36	0.882 22	0.628 16			
	K	Round	in mm	1.13 29	1.654 42		1.417 36			0.252 6	1.252 32	1.13 29

* STANDARD INSERT

CV ACTUATION SIZING GUIDE

The seat material used, media, temperature, frequency of operation and critical application of the valve's operation are all important factors in calculating the actuation needs of a given valve. The information provided below should be considered as a guide only and must be adjusted according to experience and judgement. Proper actuator selection is required to prevent valve or process equipment damage as well as proper valve operation.

Valve Torque

The torque requirements of Quarter Turn Valves will vary depending on several factors.

- **Seat design and material**

The seat friction force depends on the seat material and the applicable service factor multipliers shown in the chart below.

- **Stem Seal**

Torque results from the stem contact with stem seals and the type of packing materials affect torque. Stem seal torque needs to be considered as a percentage of overall torque especially in small valve sizes.

Service Conditions To Consider

- **Differential Pressure** Minimum and maximum pressures
- **Frequency of Operation**
- **Media Influence Slurries** dry gases, oils
- **Temperatures** Minimum and maximums
- **Cycle Time** Line hammer, process requirements
- **Instrument Air Supply** Peak demand pressure availability

Media and Service Factors

To establish minimum torque requirements, multiply valve torque by the following application media and service factors.

Media Factors	Multiplier	Service Factor	Multiplier
Clean particle free, non-lubricating (water, alcohol or solvents)	1.00	Simple On and Off Operations	1.00
Slurries or heavily corroded and contaminated systems	1.80	Throttling	1.20
Gas or saturated steam, clean and wet	1.00	Positioner Control	1.50
Gas or superheated steam, clean and dry	1.30	Once per day session	1.20
Gas, dirty unfiltered e.g. natural gas, chlorine	1.20 to 1.50	Once every two days or more or plant critical	1.50

HOW TO ORDER

Actuator Model	Action		No. of Springs	Insert Options	Options		
XL040	DA	Double Acting	5	1	P1	High temperature actuator 300°F	
XL050			6	2	P2	Low temperature actuator -40°F	
XL063			7	3	P3	Electroless Nickel Treatment	
XL075			8	4	P4	Epoxy Coating	
XL085	SR	Spring Return	9	5	P5	3 Position Actuator	
XL100			10	6	P6	Actuator Locking Device	
XL115			11	7	P7	Reverse Rotation	
XL125			12	8	P8	180° Actuator	
XL145							
XL160							
XL180							
XL200							
XL240							
XL265							
XL300							
XL350							
XL400							

Insert : See standard insert chart